

Hako-Citymaster 1250

Maintenance Schedule

Activity	Interval	
	Daily	Weekly
Cleaning of the machine as required	o	o
Check the engine oil level, if necessary top up	o	o
Check the coolant level in the compensation tank, if necessary top up	o	o
Check the the fuel level, if necessary top it up	o	o
Check the solution nozzle on the vacuum nozzle, if necessary clean it	o	o
Check the maintenance indicator for the air filter, if necessary clean it	o	o
Check the combined cooler for the engine, if necessary clean it	o	o
Check the the level for the windscreen washer fluid, if necessary top up	o	o
Empty the water separator		o
Check the cabin air filter, if necessary clean it		o
Grease the lubrication points as described in the lubrication schedule		o
Check the hydraulic oil level; refill as necessary		o
Check the lighting system		o
Check the air pressure in the tires		o
Check sweeping unit / scrubber unit for wear and damage Check sweeping pattern, adjust if necessary Check the spray nozzles, spray nozzle filters and strainers in the water system, if necessary clean them		o
Check vacuum nozzle for wear and damage Check the vacuum nozzle adjustment, if necessary adjust it Check the suction hose for wear and proper installation Check the seal between the suction hose and the dirt hopper Check the solution nozzle and the circulation water system on the vacuum nozzle Check the vacuum nozzle flap		o
Test drive with braking test		o

Greasing points

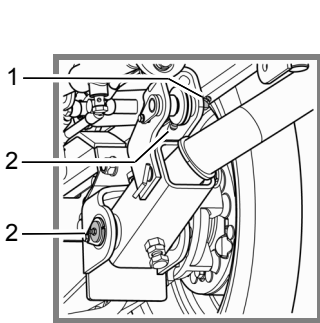
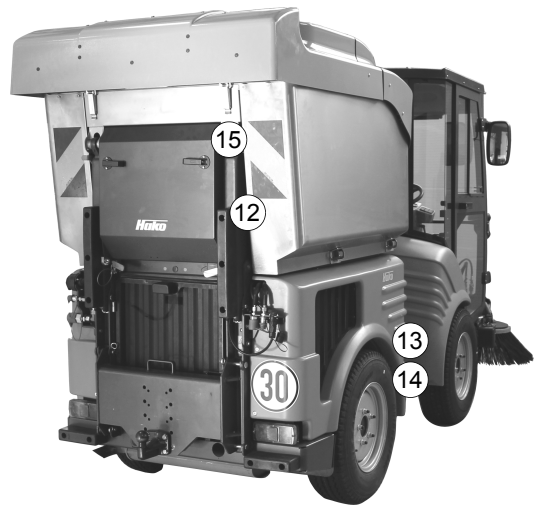

Front lifting point (8x)

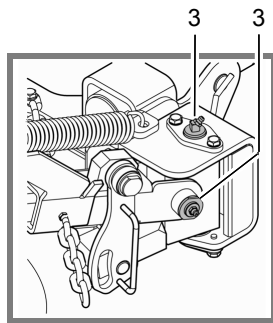

Circular brushes (4x)

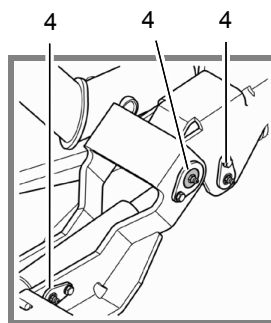

Vacuum nozzle lifting point (3x)

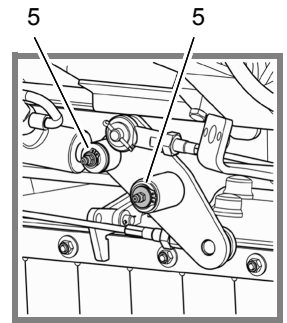

Circular brushes (2x)

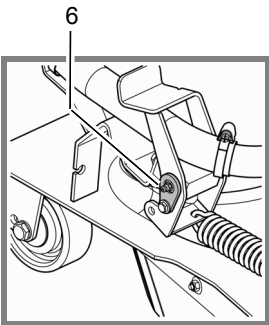

Circulation water lever (1x)

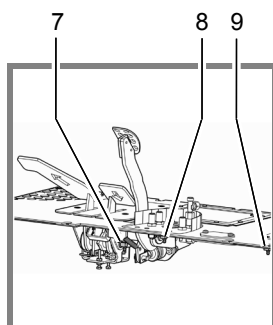

Pedal (3x)

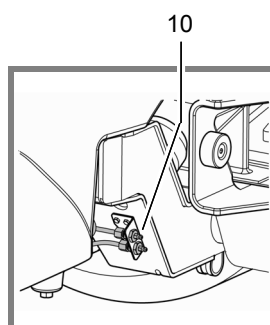

Greasing support (2x)

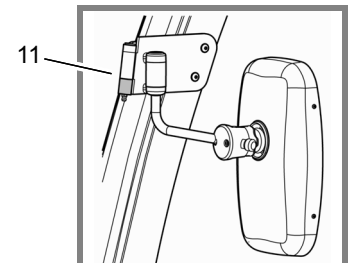

Wing mirror (2x)

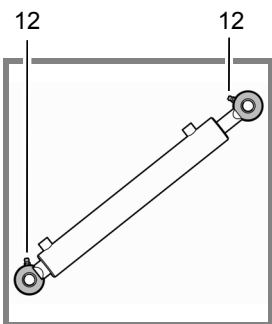

Lifting point cylinder (4x)

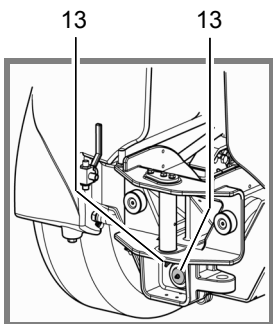

Articulated joint (2x)

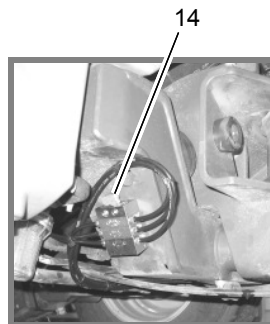

Easy grease (optional)

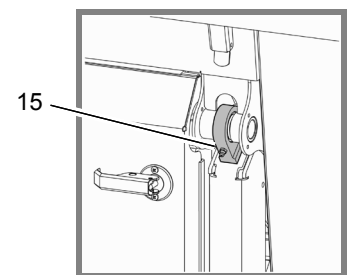

Rear support (2x)